

Rules and Regulations/Design Guidelines Eagle Brook Meadows

Loveland, Colorado

Dated 9/24/20

The Eagle Brook Meadows ("Community") property is also subject to Declaration of Covenants, Conditions, And Restrictions For Eagle Brook Meadows, City of Loveland, Larimer County, Colorado ("Covenants") which contain further restrictions and limitations, and are also binding on all lot owners within the Community. The Architectural Review Committee ("ARC") shall have the right, power, and authority to amend these Rules and Regulations from time to time as deemed appropriate in the future. In the event any provision of these Design Guidelines conflict with the provisions of the Covenants, the provisions of the Covenants shall control.

Introduction:

Pursuant to Article 7, Section 7.2 of the Covenants, the ARC may adopt Design Guidelines to facilitate the purposes and intent of the Declaration. This includes promulgation, amending, varying, repealing, or augmenting the Design Guidelines from time to time in furtherance of the Covenants. Such guidelines and rules adopted by the ARC shall have the same force and effect as if they were set forth in and were a part of the Declaration.

Accessory Buildings, Storage Buildings: Accessory buildings and storage buildings shall be submitted to and approved by the ARC prior to their construction. All such buildings shall be consistent with the siding, roofing and exterior color palette of the primary residence. All accessory buildings and storage buildings shall be located within the side or rear yard of the primary residence in accordance with the PUD zoning standards for Eagle Brook Meadows as approved by the City of Loveland ("City").

Additions and Expansions: Any additions and/or expansions modifying the exterior of any existing structure require prior approval of the ARC.

Advertising: See "Signs".

Air Conditioning Equipment: No types of refrigerating, cooling or heating apparatus shall be permitted on the roof or in any window of any existing structure unless such system is approved in writing by the ARC. Further, no such apparatus shall be permitted elsewhere on a lot unless appropriately screened and approved by the ARC. Without limiting the foregoing, conventional air conditioning units located on the ground of a lot are permissible when approved in accordance with the preceding sentence.

Antennas: Except as otherwise provided herein, no exterior radio antenna, television antenna, satellite dish, aerial or other reception device or other antennae of any type or size shall be erected or maintained on the lot without the prior approval of the ARC. Satellite dishes may be installed below the roof line of any Residence, provided that the satellite dish is not visible from the street. The ARC shall act on applications for approval of satellite dishes and antennas in accordance with the requirements of the Federal Telecommunications Act of 1996, and any applicable regulations adopted pursuant thereto, as such statute and regulations may be amended from time to time. Antennae may be erected within the enclosed attic space of the residence.

Artificial Turf: Artificial Turf is allowed in rear yards only up to 25% of the rear yard, per the City of Loveland Municipal Code 18.08.06.01 regarding Trees, Ground Covers, and Mulch.

Awnings: Cloth or canvas awnings require prior ARC approval. Color must be the same as or generally recognized as complementary to, the primary residence exterior color palette and must be integrated in the overall appearance of the home. Awnings (cloth or canvas)/coverings may be used over a patio or deck in the rear yard of the residence only. Awnings (cloth or canvas) shall be maintained in good condition and appearance. No aluminum, fiberglass, or bolt-on type awnings will be allowed.

Balconies: Construction of a balcony must receive prior approval by the ARC.

Basketball Backboards: Placement on the home is prohibited. Free-standing basketball backboards permanently installed along the driveway are allowed with approval by the ARC. Portable basketball hoops will be allowed with the following conditions: It must be stored out of view from the street when not in use during the months of October through April. The portable basketball standard must be in good condition if left out during the warm season months (May through September). The portable basketball standard must not be used or stored on the public street or the sidewalk.

Bird Houses and Feeders: Bird houses and feeders do not require ARC approval up to a maximum size of 1 foot by 2 feet. No bird houses or bird feeders (of any size) may be attached to fencing.

Boats: Boats and boat trailers shall not be parked on the streets of the Community or stored on any lot unless fully contained within a garage. Notwithstanding the foregoing, boats and boat trailers may be parked upon the driveway of the lot or upon the street immediately adjacent to the lot for expedient loading or unloading not to exceed 48 hours.

Carports: Free standing carports are not allowed.

Clotheslines: No clotheslines shall be installed or maintained on any lot.

Concrete: It is recommended that only a neutral tone concrete be used for all concrete work. Tinted, colored or stamped concrete will be allowed only with specific approval by the ARC.

Construction Staging and Materials Storage: Construction materials, including trash and/or storage containers, may not be placed on any lot or street without ARC permission. Additionally, storage of construction materials (including storage containers) are only permitted 7 days prior to the beginning of construction within the development and must be removed within 14 days of construction completion. Utility trailers are not permitted for storage purposes. All containers must be in good condition and the amount of materials stored must not exceed the amount required for the current project.

Doghouses: Doghouses require plan submittal to the ARC prior to installation/construction. This also includes dog runs. Also, doghouse and dog runs must be appropriately concealed from the street and neighboring yards. Acceptable methods of concealment include fencing or other screening methods as may be approved by the ARC.

Driveways: Driveways from the public street to the garage of the home shall be constructed only with neutral tone (standard grey) concrete unless otherwise approved by the ARC. There shall be no extension or expansion to a driveway without prior ARC approval. If driveway extension or expansion is desired, drawings shall be submitted to the ARC showing the desired changes/additions (also including description of proposed materials).

Evaporative Coolers: Evaporative coolers are not allowed.

Fences: Fences require ARC approval prior to installation. Drawings showing fence location, layout, design, height, and material shall be in accordance with the COMMUNITY FENCING PLAN and shall be

submitted to the ARC for approval. No fencing will be allowed anywhere within the front yard of residence. Only property perimeter fencing of the side and rear yard of residence will be allowed.

See Exhibit A – COMMUNITY FENCING PLAN

Flagpoles: Free standing flag poles are not allowed. One wall mounted bracket per residence shall be allowed without approval.

Gardens: Vegetable gardens shall be allowed only within the homeowner's side or back yard and shall be screened from view of neighboring property. Flower gardens and other landscaping gardens are encouraged but shall require prior ARC approval and be submitted on an original landscaping plan, or submitted as a change request if performed after original landscaping plans have been approved by the ARC.

Greenhouses: Greenhouses require prior ARC approval.

Hot Tubs/Spa Tubs: Hot tubs/spa tubs shall require prior ARC approval. Hot tubs/spa tubs should be an integral part of the deck or patio area and within the rear yard landscaping, and shall not be immediately visible from the front yard or adjacent streets. Hot tubs/spa tubs shall be located and installed in such a manner that they will not cause noise disturbance to adjacent property owners. Owners shall take all necessary precautions to prevent accidental drownings, including appropriate tub covers.

Landscaping: Applications for initial rear yard landscaping and installation of the same are required to commence within six (6) months and be complete within one (1) year of closing on the home. Landscaping plans must be approved by the ARC prior to installation. Once a landscaping plan has been approved, no alterations can be made to that plan unless such alteration is submitted and approved by the ARC. The ARC may require form(s) to accompany submitted landscaping plans and payment of a review fee. Underground, automatic irrigation systems must be installed to irrigate landscaping in the front and rear yards. Landscape Plans shall depict types and locations of: fencing, decks, playground areas, sod, seeded areas, edging, retaining walls, rock areas, landscape timbers, underground, automatic irrigation systems, species and sizes of living plant materials, flower beds/gardens, other planting beds, mulch areas, landscape lighting and any other components intended for installation. Lot owners are responsible for replacing dead or diseased trees or plantings. No more than 30% of the front yard landscaping shall be non-living materials unless otherwise approved by the ARC and the City. The same standard shall apply to back yards unless the entire back yard is screened from view by fencing or other screening materials approved by the ARC and is no less than 5' high. Landscaping work/installation can be accomplished by a professional landscaping designer/contractor, by construction contractor, or by residence owner(s). The ARC may approve extensions to the installation deadline on a case by case basis when a good faith effort has been made to comply with the installation timeline and extraordinary circumstances exist.

Per the approved Public Improvement Construction Plans (PICP's) for Eagle Brook Meadows First Subdivision, all trees, shrubs groundcover, and other plant material used for landscaping within Eagle Brook Meadows shall be in conformance with the City's approved Plant List found within the Title 18 Unified Development Code, Part 5, Appendix A.

http://online.encodeplus.com/regs/loveland-co/media/files/plant_list_5_21_2018.pdf

Front Yard Living Plant Material Minimums

1 Tree (Deciduous or Evergreen) 2 inch minimum caliper trunk
5 Shrubs

Rear Yard Living Plant Material Minimums Based on Lot Size as Measured Across the Width of the Rear Yard

Small (50 feet wide or less)

1 Tree (Deciduous) 1.5 inch minimum caliper trunk
4 Shrubs

Standard (50 feet wide to 75 feet wide)

1 Tree (Deciduous or Evergreen) 1.5 inch minimum caliper trunk
5 Shrubs

Large (75 feet wide or larger)

2 Trees (One Deciduous, the second either Deciduous or Evergreen) 1.5 inch minimum caliper trunk
9 Shrubs

Living Plant Material Minimum Size Requirements

Deciduous Trees: Front Yard = 2 inch minimum caliper trunk. Rear Yard = 1.5 inch minimum caliper trunk

Ornamental Trees: Rear Yard = 1.5 inch minimum caliper trunk

Evergreen Trees: 6-foot height or greater

Shrubs: 5-gallon size (aka #5) container

Weeds on all lots (including, without limitation, lots owned by builders) shall be kept mowed/cut when they exceed 4 inches in height. Maintenance of all landscape elements is required (example: if an area is designed as a rock mulch bed, it should be maintained to be free of weeds and grasses).

Lattice Work: Lattice work shall require prior ARC approval. Any lattice work shall be incorporated within the "general" landscaping theme and must be maintained in good condition and appearance.

Lights and Lighting: Lights and lighting shall be designed, installed, and operated to provide safe and adequate views without creating a nuisance or hazard to adjacent lots, streets or other Community property. Lighting for walkways shall be directed to the ground. Use of "Dark Sky" compliant lighting is encouraged. Addition of any exterior lighting or replacement of any exterior fixtures installed during the initial build shall be approved by the ARC.

Ornaments: Ornaments, such as fountains, statues, artificial plants, wagon wheels or equipment, or any other such ornamental features shall not be placed or allowed to remain where visible from streets or adjoining lots, or where such ornaments exceed the height of fence lines, unless the same have been approved by the ARC.

Overhangs (Cloth or Canvas): See "Awnings" or "Patio Coverings"

Painting: All exterior painting of residences shall be kept in good condition and in the colors approved with the original construction submittal. Color changes thereafter must be prior approved by the ARC. Physical color swatches/samples of the proposed colors identifying the location on the home they will be applied shall be submitted along with photos of a) the home to be painted, and b) the neighboring homes on the immediate right and left of the home to be painted. The ARC will not approve similar paint schemes on neighboring homes.

Patio Coverings: Patio coverings must be approved by ARC. They must be constructed of wood or materials generally recognized as complementary to the residence and must be similar or generally recognized as complementary in color to the primary residence color palette.

Paving and Hardscapes: Hardscapes can be created with a variety of materials and used to enhance the residences landscaping or to create patio areas, walkways, stoops, porches, edges, etc. Approved materials are as follows: neutral tones of concrete or stamped concrete, flagstone, steppingstones, pre-cast patterned or exposed aggregate concrete pavers, and colored or natural rock. All material must be installed/located so as not to block any existing drainage pattern of the lot. All hardscape materials will require prior ARC approval to ensure they blend with the palette of the community. Example pictures of

materials proposed to be installed are highly encouraged to be submitted with your ARC application.

Play and Sports Equipment: Play and sports equipment requires prior ARC approval. In general, all play equipment, trampolines and other sports equipment shall only be allowed in the rear yard of a residence. The ARC may require screening from the street or adjacent lots.

Playhouses: Playhouses require prior ARC approval. Playhouses shall not exceed 6' in height at the peak, shall have no more than 100 square feet of interior floor space, and shall be located in the rear yard of the residence. Basic design, materials, colors, and roof materials must match the residence. Playhouses are to be incorporated into, and at least partially screened by, adjacent landscaping.

Pools: All swimming pools (whether in ground or above ground) shall require prior ARC approval. Moveable small children size swimming pools (12' in diameter or less and 18" in depth or less) need not receive ARC approval. Swimming pools may be located only in the rear yard of a residence. It is strongly recommended that some form of protection be installed surrounding all swimming pools (such as fencing – also subject to ARC approval) to protect against accidental drownings.

Recreation Vehicles/ Campers: Except as otherwise set forth in these Rules and Regulations, recreational vehicles such as motor homes, trailers, campers, boats and other watercraft, golf carts, and boat trailers shall be parked only in enclosed garages or specific areas, if any, which may be designated by the District from time to time. Additionally, oversized commercial vehicles shall be prohibited from parking on any lot or Community streets without the prior consent of the District and/or the City. This restriction, however, shall not prohibit vehicles (including, without limitation, emergency vehicles driven by an on or off duty employee of the entity providing emergency services) that may be parked on a temporary basis for loading, delivery, emergency or for any other lawful purpose.

Retaining Walls: Retaining walls require prior approval of ARC. Also see "Landscaping."

Roof Top Equipment: No roof top equipment is allowed (see also "Air Conditioning Equipment" and "Antennae"). Decorative roof mounted weathervanes require prior ARC approval.

Satellite Dishes: Satellite dishes may be installed below the roof line or on the rear facing roof of any residence without ARC approval, provided that the satellite dish is not visible from the street. Also see "Antennae."

Seasonal Decorations: Seasonal decorations are permitted with the following qualifications and conditions: (i) Christmas decorations shall not be displayed prior to November 10 and must be removed by January 25 of the following year; (ii) other holiday decorations shall not be displayed earlier than 30 days prior to the celebrated holiday and must be removed within two weeks thereafter; (iii) no decorations shall be displayed in such a manner as to be offensive to the Community or create a public nuisance.

Signs: Except as may be expressly permitted by applicable law, and including these Rules and Regulations, no signs or flags shall be displayed to the public view on any lot without the prior written approval of the ARC, with the following exceptions: (i) The patriotic display of flags not exceeding 4' X 6' and signs of customary dimensions, not exceeding 3' X 4' in size, advertising a lot or portion thereof as "For Sale" or "For Rent" shall be exempt. No electronic signs shall be permitted on any lot if the same would be visible from the outside of the structure containing such sign. Notwithstanding anything contained herein to the contrary, all signs shall comply with local (City) signage ordinances.

Solar Energy Devices: Solar Energy Devices (whether passive or active) require prior approval from the ARC. Devices must be designed to appear as if they are an integral part of the roof. Every attempt shall be made to mount such devices on the back side of roof if possible, to minimize visibility from front of the residence and the adjoining street.

Swamp Coolers: See "Evaporative Coolers."

Swing Sets: See "Play and Sports Equipment."

Television Antennae: Television antennae are not allowed to be mounted anywhere on the exterior of the residence. Also see "Antennae" and "Satellite Dishes."

Temporary Structures: Temporary structures are not allowed.

Utility Trailers: Utility trailers shall not be parked on the streets within the Community or stored on any lot unless fully contained within a garage.

Vehicles: Except as otherwise set forth in these Rules and Regulations, vehicles shall be parked only in garages or on driveways serving the lots, or within designated parking spaces or areas which may be designated by the District from time to time. Vehicles may be parked on a temporary basis for resident visitations, loading, delivery, or emergency purposes and may be further subject to City ordinance and enforcement.



Exhibit A
COMMUNITY FENCING PLAN
Fence Type by Lot

EXHIBIT – COMMUNITY FENCING PLAN

PHASE 1, 2 AND 3

EAGLE BROOK MEADOWS

LEGEND

-  PROJECT BOUNDARY
-  LOTS ELIGIBLE FOR SIDE YARD 5' PRIVACY FENCE ABUTTING EXISTING THREE RAIL FENCE AT REAR OF LOT
-  LOTS ELIGIBLE FOR 5' PRIVACY FENCE ONLY

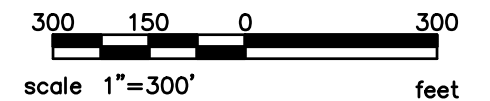
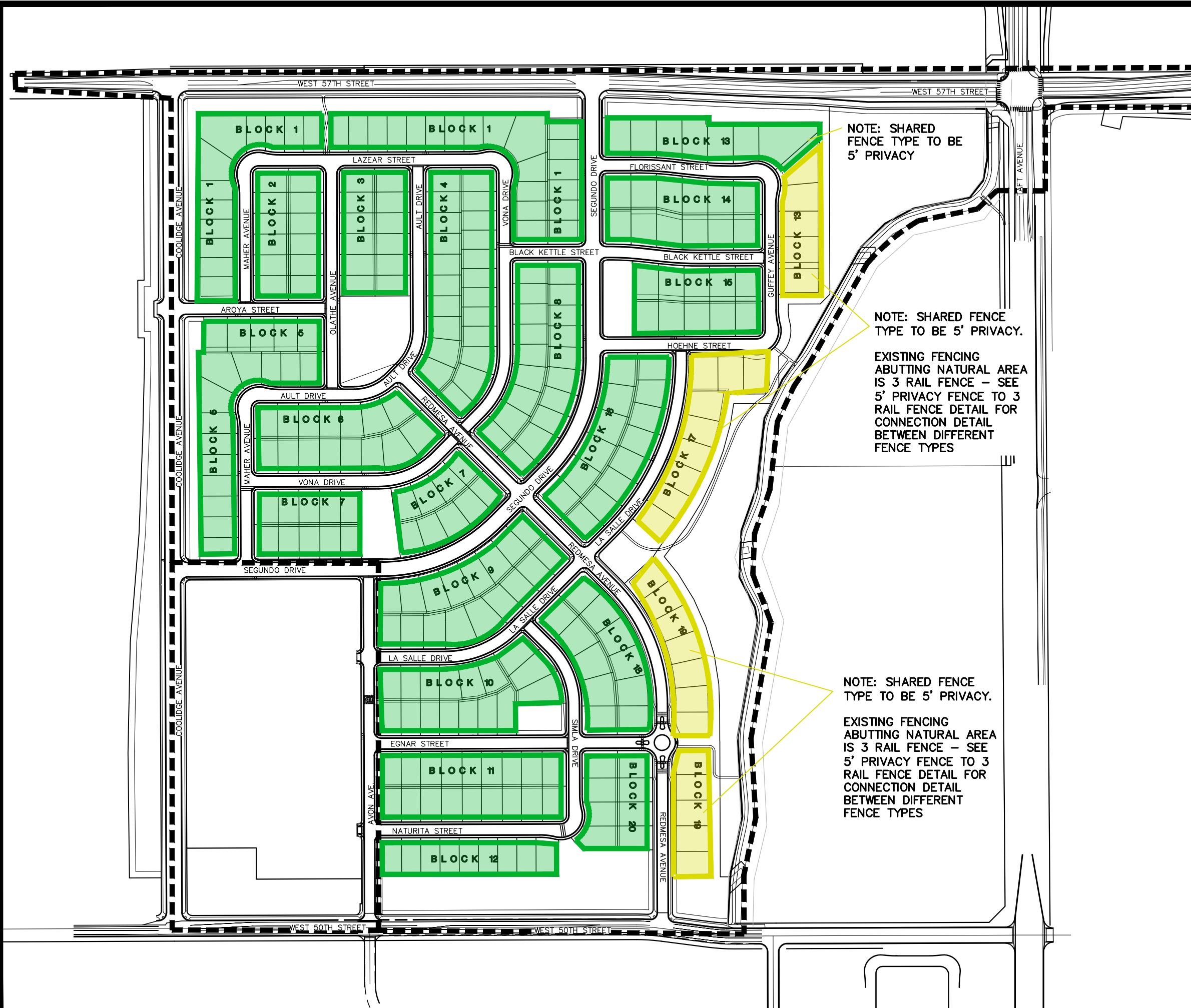

PREPARED BY:
TST, INC. CONSULTING ENGINEERS
 748 Whalers Way, Suite 200
 Fort Collins, Colorado
 Phone: 970.226.0557
 Fax: 970.226.0204
 Job no. 1171.0001.01
 Filename: Fencing Exhibits
 July 24, 2020

EXHIBIT – COMMUNITY FENCING PLAN–DETAILS

PHASE 1, 2 AND 3

EAGLE BROOK MEADOWS

NOTES:

1. VERIFY EXISTING FENCING DIMENSIONS BEFORE INSTALLATION AND ADJUST AS REQUIRED.
2. ALL WOOD SHALL BE CEDAR PAINTED WITH – BENJAMIN MOORE PRODUCT BM-211-20, GRIZZLY BEAR BROWN.
3. SIDE YARD PRIVACY FENCING – IF SIDE YARD FENCE DOES NOT ALIGN WITH EXISTING 3 RAIL FENCE POSTS, ADDITIONAL 4" X 4" POST WILL NEED TO BE INSTALLED AT SIDE YARD PRIVACY FENCE CONNECTION TO EXISTING 3 RAIL FENCING.

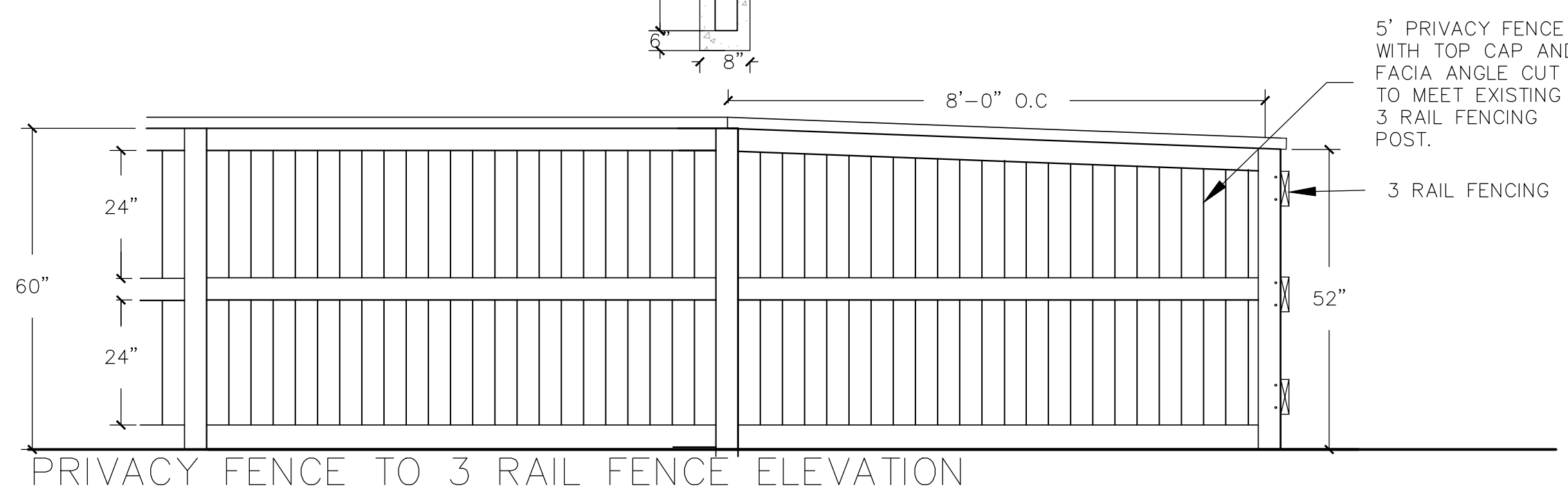
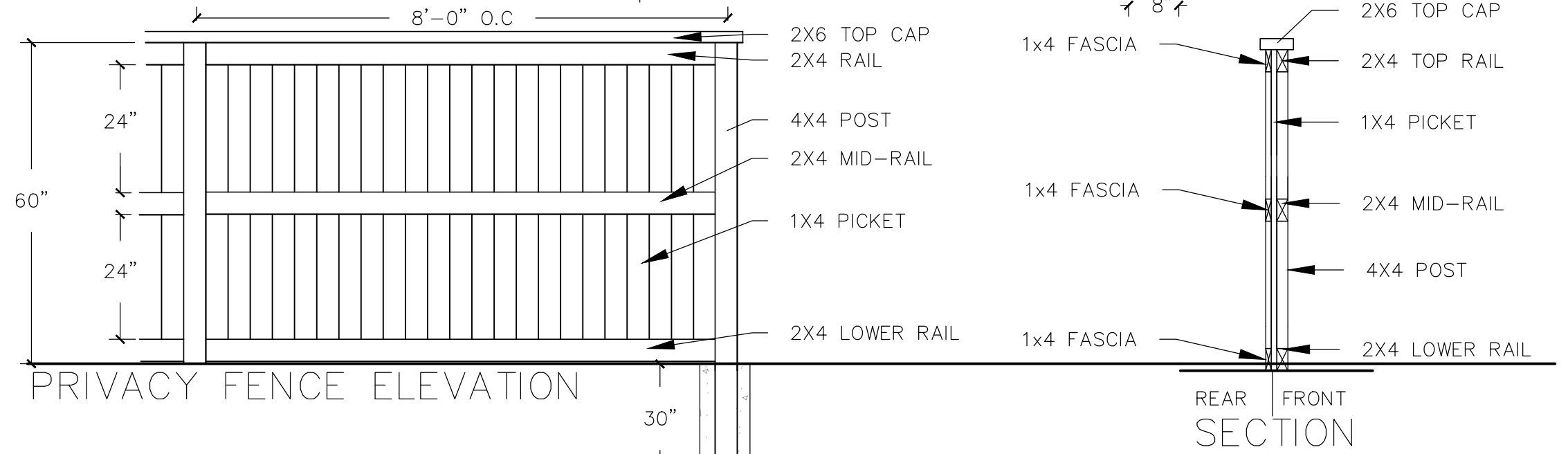
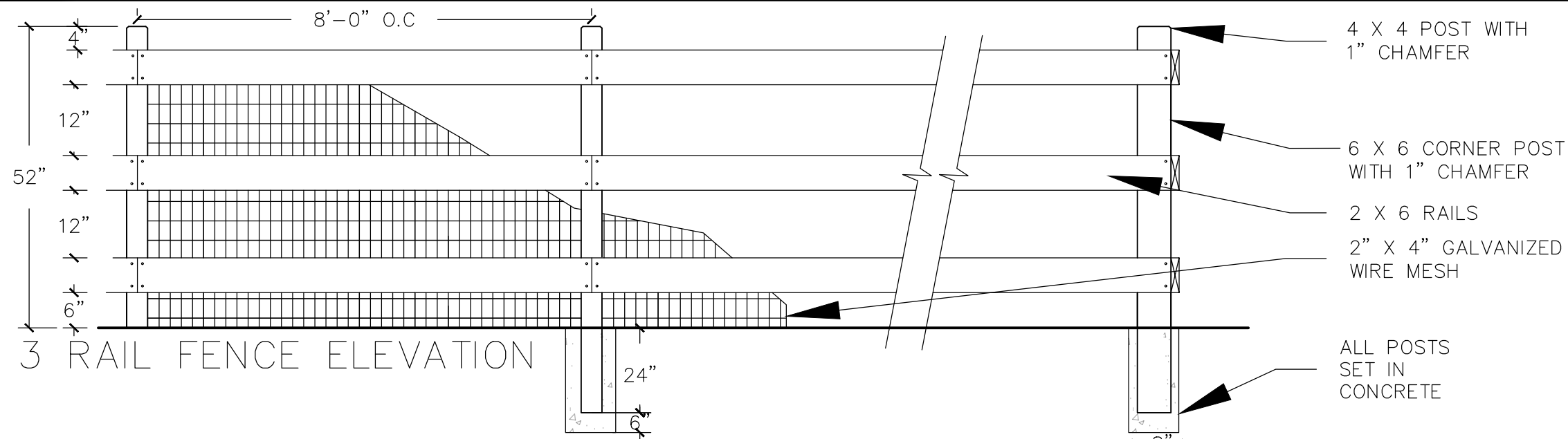

PREPARED BY:
TST, INC. CONSULTING ENGINEERS
 748 Whalers Way, Suite 200
 Fort Collins, Colorado
 Phone: 970.226.0557
 Fax: 970.226.0204
 Job no. 1171.0001.01
 Filename: Fencing Exhibits
 July 30, 2020